



Relief valve, direct acting
(VS-80 Bosch Rexroth)

Type

RELIEF VALVES

FVLP-26

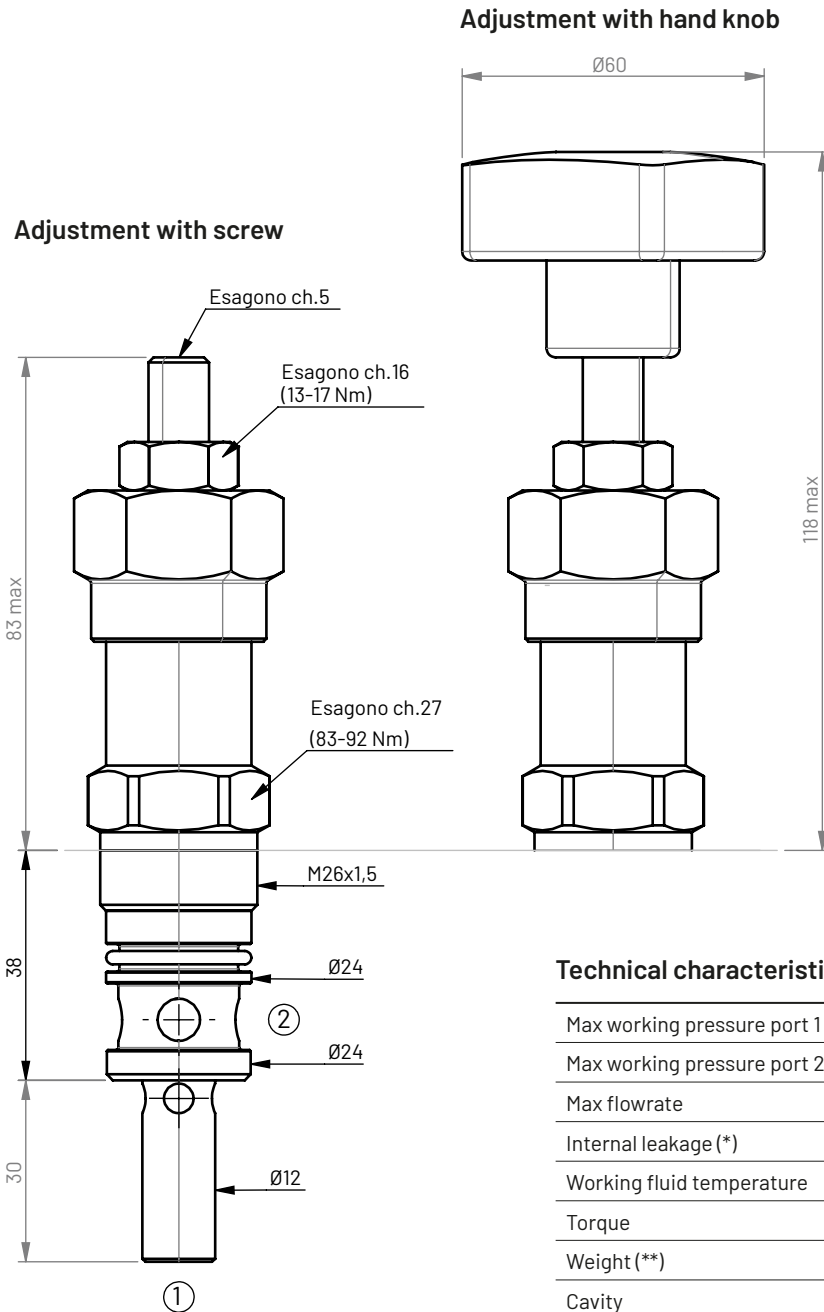

Hydraulic circuit

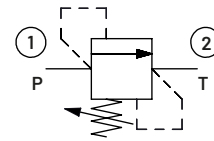

Characteristic curve

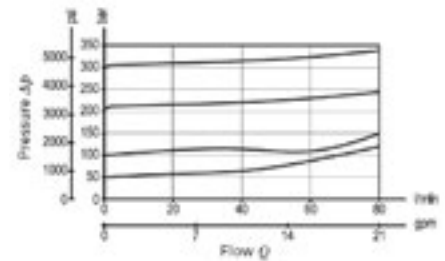

Technical characteristics

Max working pressure port 1 (P)	350 bar
Max working pressure port 2 (T)	140 bar
Max flowrate	80 l/min
Internal leakage (*)	15 drops/min
Working fluid temperature	-30 / +100 °C
Torque	83÷92 Nm
Weight (**)	0,35 kg
Cavity	C26 (see p. 20.3)
Cavity plug	FVTA260000000 (see p. 10.2)
Fluid	mineral or synthetic base with lubricating properties, viscosity between 10 and 500 cSt
Degree of fluid contamination	Max. nominal value 10 µm (NAS 8) ISO 4406 19/17/14

(*) At 80% of the calibration pressure

(**) Standard version with screw adjustment