

CETOP3 - NG6

360

Model CBA360*-I

Type
Model

Connecting accessory block
for modular systems (71x71)

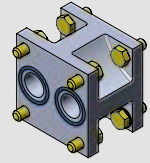

3.6

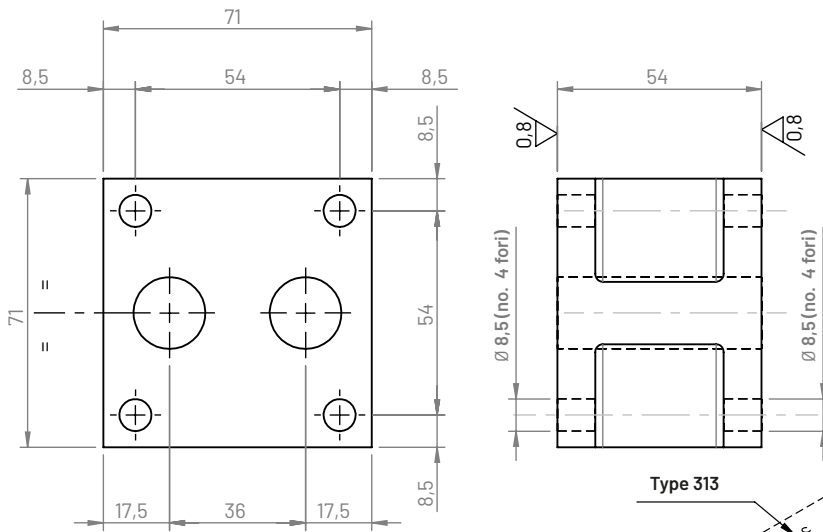

Mounting example

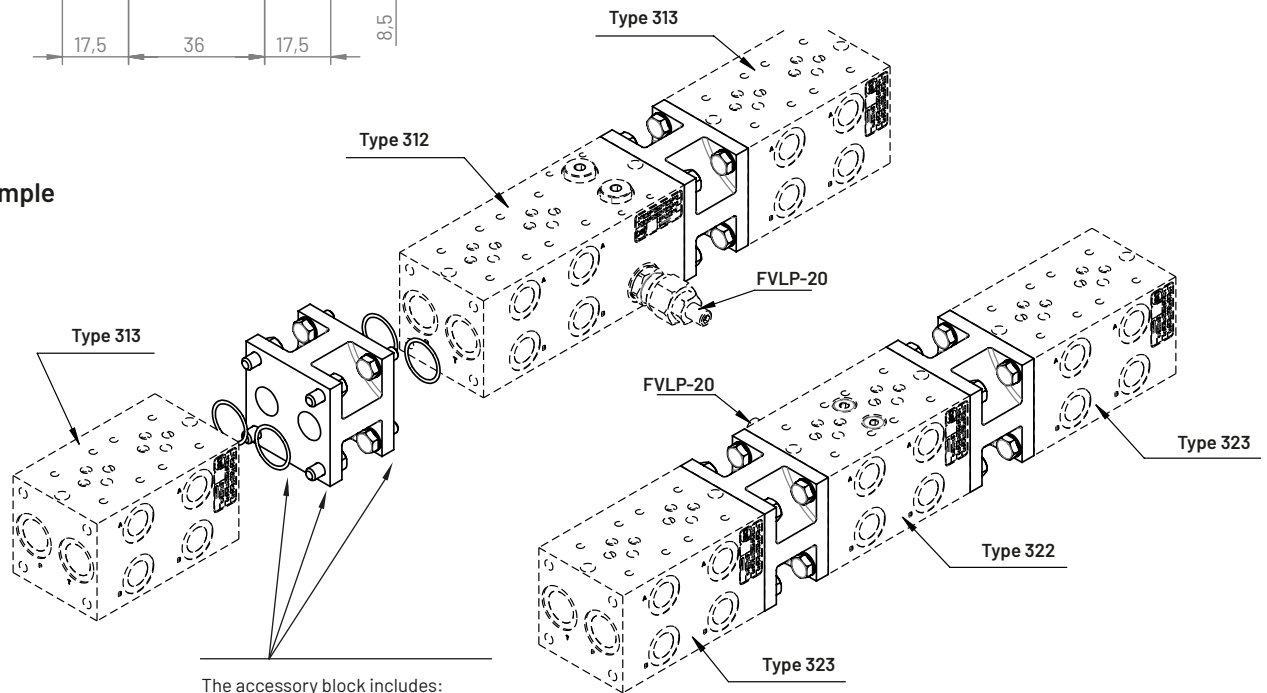

The accessory block includes:
 - no. 8 screws M8x20 UNI5739
 - no. 8 washers Ø8 DIN6798A
 - no. 4 O-Rings 2106 (26,70x1,78) NBR90

Hydraulic circuit

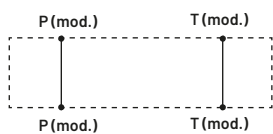

Weight

Aluminum (kg)	Cast iron (kg)
0,5	1,75

Ordering code

CBA 3 60 * - I

Connecting accessory block: **CBA**

Flange CETOP: **3**

Configuration type: **60**

Material:

G (Phosphated cast iron GJL250)



A (aluminum EN AW-6026 LF without anodization)

B (aluminum EN AW-6026 LF with neutral anodization)

Other materials on demand

Position: **I** (central)