

Panel accessory block
for modular system (71 x71)

Type
Model

CETOP3 - NG6

360
CBA360*-E

ACCESSORY
BLOCK

3.5

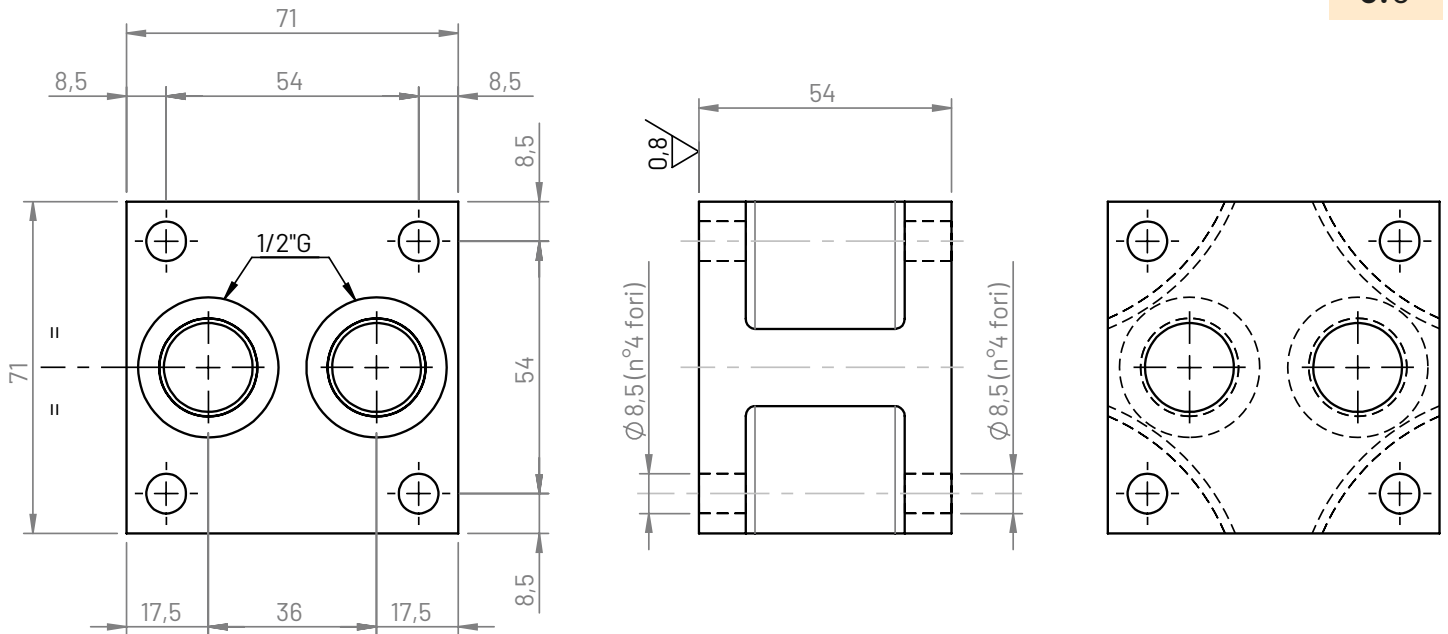

Mounting example

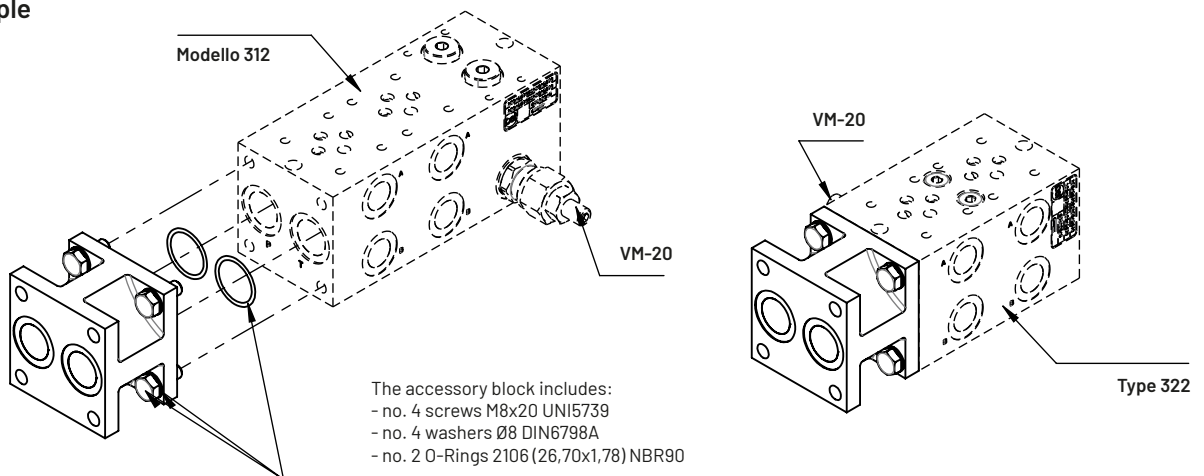

Hydraulic circuit

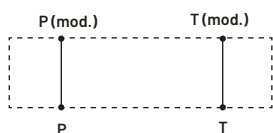

Weight

Aluminum (kg)	Cast iron (kg)
0,5	1,25

Ordering code

CBA 3 60 * - E

Panel accessory block: **CBA**

Flange CETOP: **3**

Configuration type: **60**

Material:

G (Phosphated cast iron GJL250)

A (aluminum EN AW-6026 LF without anodization)

B (aluminum EN AW-6026 LF with neutral anodization)

Other materials on demand

Position: **E** (entry)