

CETOP3 - NG6

Type
Model

351
CBA351*-***

Upper accessory block
with solenoid valve (VE-08)
for modular systems

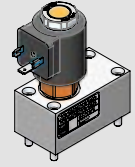

3.3

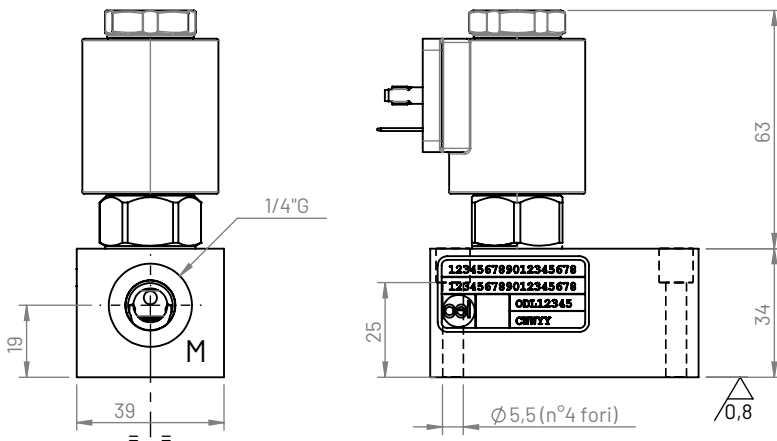
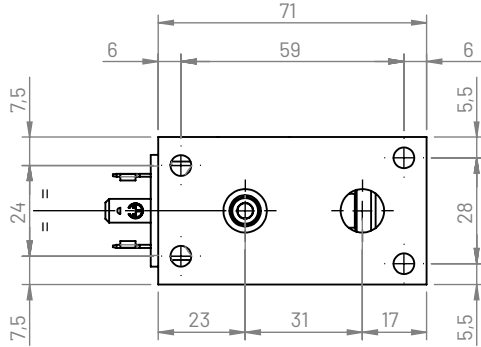

Mounting example

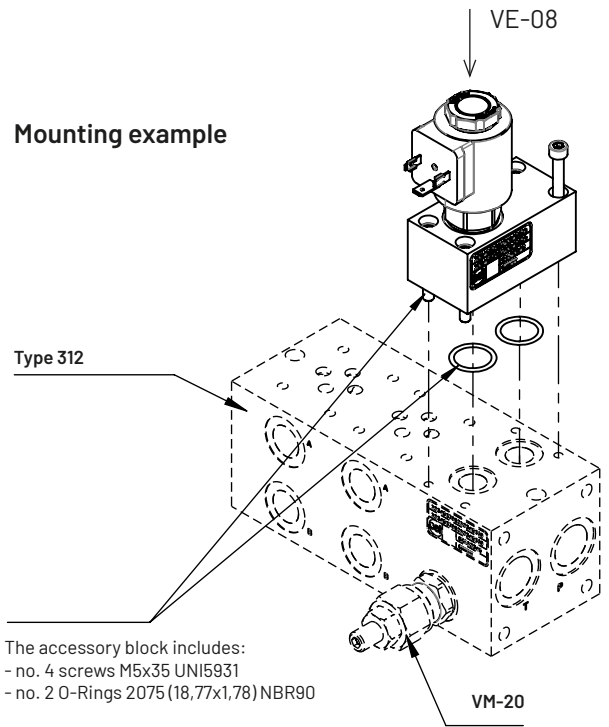

The accessory block includes:
- no. 4 screws M5x35 UNI5931
- no. 2 O-Rings 2075 (18,77x1,78) NBR90

Hydraulic circuit

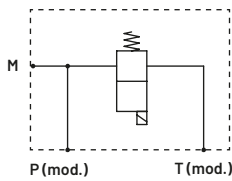

Weight

Aluminum (kg)	Cast iron (kg)
0,55	0,9

Ordering code

CBA 3 51 * - * * *

Accessory block: **CBA**

Flange CETOP: **3**

Configuration type: **51**

Material:

G (Phosphated cast iron GJL250)

A (aluminum EN AW-6026 LF without anodization)

B (aluminum EN AW-6026 LF with neutral anodization)

Other materials on demand

VE-08 present:

V (included) technical info → p. 8.1

L (with cavity open)

T (with cavity plugged)

VE-08 type (omit with L-T present)

A (normally open)

C (normally closed)

Coil type (omit with L-T present):

A (no coil)

B (with coil 12Vdc)

C (with coil 24Vdc)