

Left side accessory block with solenoid valve (VE-08) for modular systems

CETOP3 - NG6

Type
Model

350
CBA350*-***-S

ACCESSORY
BLOCK

3.2

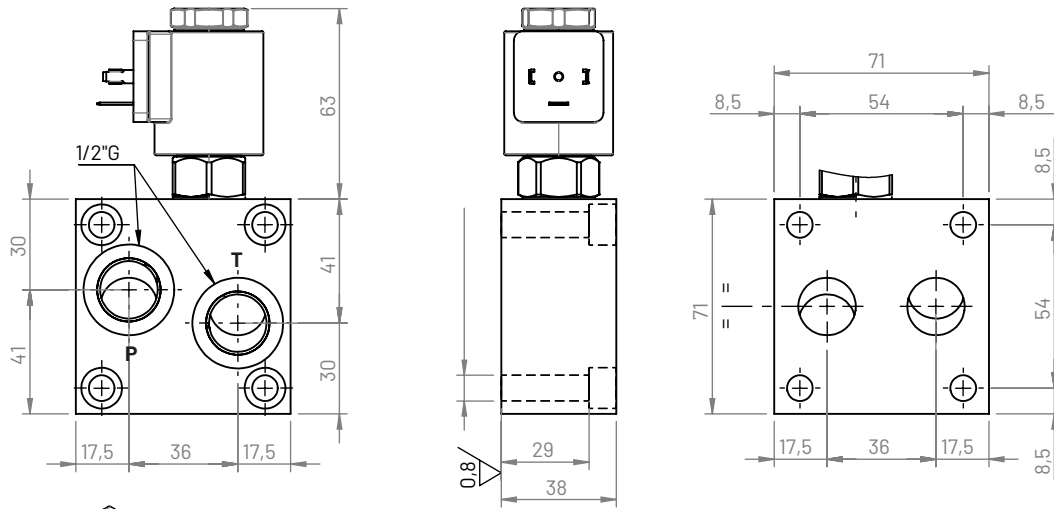

Mounting example:

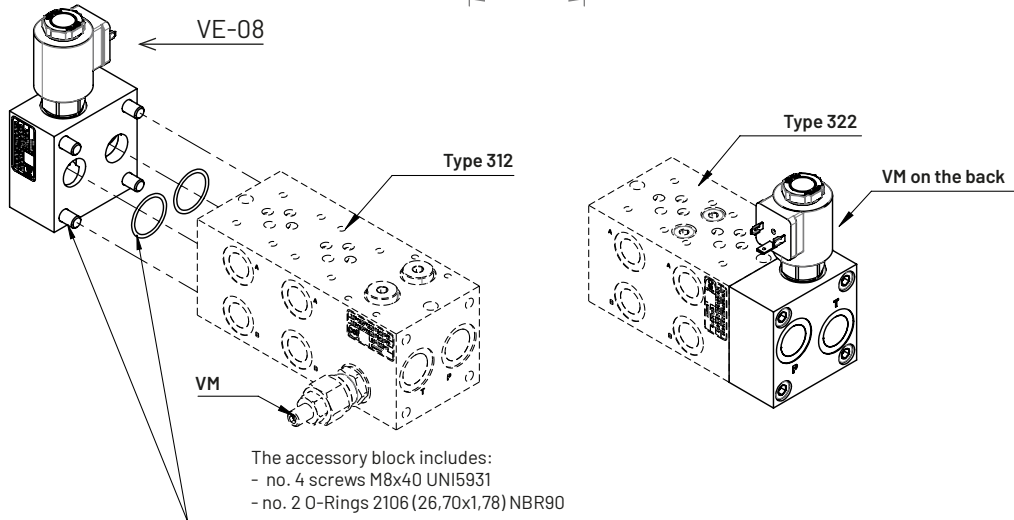

The accessory block includes:
- no. 4 screws M8x40 UNI5931
- no. 2 O-Rings 2106 (26,70x1,78) NBR90

Hydraulic circuit

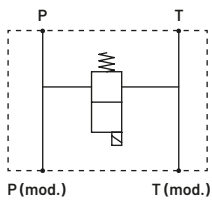

Weight

Aluminum (kg)	Cast iron (kg)
0,75	1,4

Ordering code

CBS 3 50 * - * * * - S

Accessory block: **CBS**

Flange CETOP: **3**

Configuration type: **50**

Material:

G (Phosphated cast iron GJL250)

A (aluminum EN AW-6026 LF without anodization)

B (aluminum EN AW-6026 LF with neutral anodization)

Other materials on demand

VE-08 present:

V (included) technical info → p. 8.1

L (with cavity open)

T (with cavity plugged)

VE-08 type (omit with L-T present)

A (normally open)

C (normally closed)

Coil type (omit with L-T present):

A (no coil)

B (with coil 12Vdc)

C (with coil 24Vdc)

Position: **S** (left side)